

# INSTALLATION & OPERATING INSTRUCTIONS FOR FIREVIEW™ WATER JACKETS

Elmira  
Stove  
Works

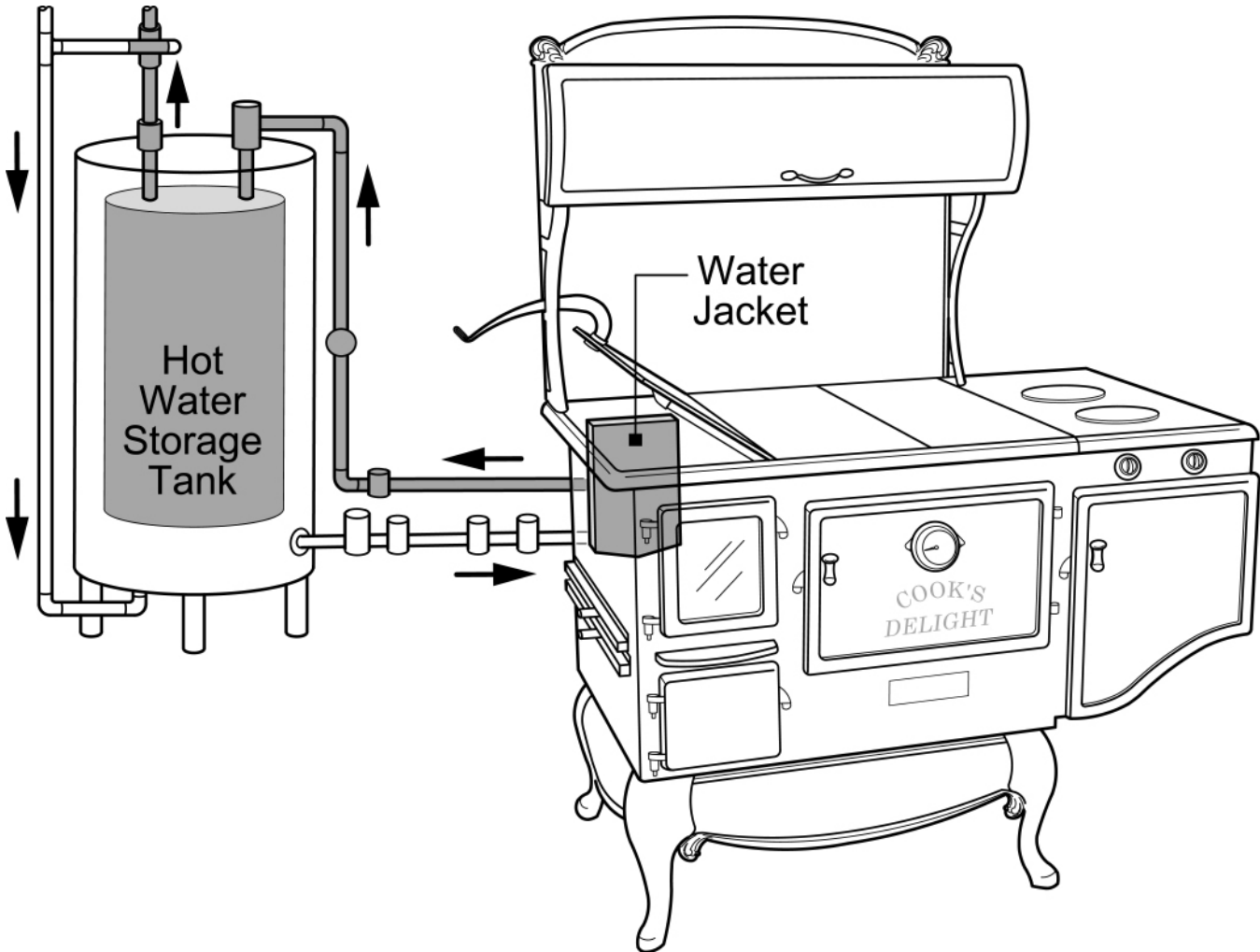

*Note: Illustration above is to show base components only. Additional components are required, as detailed in this manual. The storage tank should be elevated above the water jacket for convection / gravity systems.*

**Important! Read this entire manual before you install or use your water jacket. To reduce the risk of explosion or fire, follow the installation instructions exactly and completely. Failure to follow the instructions may result in property damage, bodily injury or even death.**

**SAVE THESE INSTRUCTIONS FOR FUTURE REFERENCE.**

# **DANGER & CAUTION**

**CAUTION: ALL WATER JACKET INSTALLATIONS MUST BE DONE BY A QUALIFIED PLUMBING CONTRACTOR.**

**CAUTION: DO NOT OPERATE YOUR STOVE WITHOUT THE WATER JACKET AND PLUMBING SYSTEM FILLED WITH WATER. AN EXPLOSION COULD RESULT. REPLACE THE WATER JACKET WITH THE REAR FIRE BRICK BEFORE OPERATING.**

**CAUTION: PRESSURE TEMPERATURE RELEASE VALVES (PTR's or PTV's) SHOULD BE TESTED AT LEAST ONCE A YEAR. PTV'S SHOULD BE REPLACED IF SPONTANEOUSLY ACTIVATED FOUR OR MORE TIMES.**

**CAUTION: PRESSURE TEMPERATURE RELEASE VALVES (PTR's or PTV's) MUST BE PLUMBED TO A DRAIN OR TO THE OUTDOORS IN SUCH A WAY THAT RELEASED HOT WATER AND STEAM CANNOT MAKE CONTACT WITH BYSTANDERS.**

**THREE PRESSURE TEMPERATURE RELEASE VALVES (PTR's or PTV's) ARE REQUIRED IN ANY SYSTEM – ONE LOCATED ON THE HOT WATER OUTLET PIPE NEAR THE TOP OF THE STORAGE TANK; ONE LOCATED WITHIN TWO FEET OF THE WATER JACKET ON THE HOT WATER OUTLET PIPE; AND A THIRD ON THE COLD WATER INTAKE PIPE WITHIN TWO FEET OF THE WATER JACKET.**

- A hot water system can explode with life-threatening consequences if not installed properly, with correctly rated and properly drained and located pressure temperature relief valves (PTV's).
- Wood-heated hot water systems produce scalding hot water and steam. Ensure your system includes an operational and properly installed tempering valve. Keep yourself, children and pets away from the faucet when turning on the hot water.
- Test and replace pressure temperature release valves according to the manufacturer's directions. Replace PTV's if spontaneously activated four or more times.
- Never cap or remove a PTV, even temporarily.
- Wood-fired hot water jackets can produce scalding hot water. A properly installed and functioning tempering valve must be installed in the hot water outlet pipe from the storage tank, to allow cold water to "temper" the heat of the hot water.
- Replace any worn or leaking components immediately, especially pressure temperature release valves and tempering valves. (Leaking valves are often a sign of excessive pressure build-up.) Discontinue operating the stove, or replace the water jacket with the original firebrick, until the defective parts are repaired or replaced.
- Do not use plastic pipe with a water jacket installation.
- Use only fittings rated for appropriate pressure and temperature extremes. Do not substitute inappropriately rated fittings.
- Calcification, corrosion and lime build-up restrict the flow of water and / or prevent pressure temperature release valves (PTV's), tempering valves, check valves, water jacket and piping from operating properly. The system and individual fittings require regular maintenance and inspection.
- Never close or cap water lines to or from the water jacket. Do not install gate valves anywhere in the system. A water jacket and associated plumbing can explode with life-threatening force if the flow of water to and from the jacket is restricted in any way.
- Never allow the water jacket or plumbing to run empty or develop air pockets. Do not operate the stove if the water jacket and system are not fully charged with water.
- DO NOT use plumbing pipes as an electrical ground.

## Introduction

Your Fireview stove is a highly efficient cooking and heating appliance. When a water jacket is added, it can provide additional energy and cost savings. Wood is a renewable resource. When harvested in a sustainable responsible manner, it can be a very eco-friendly alternative to fossil fuels. Research has shown that the same amount of carbon dioxide is produced whether wood is left in the forest to decay or harvested and burned as fire wood. With air-tight design and secondary combustion technology, the Fireview provides you with state-of-the-art efficiency. It is imperative that you read this manual thoroughly prior to installing and operating your water jacket. The diagrams and instructions must be carefully followed to ensure safe and satisfactory operation.

## Choosing the Right System

Depending on your needs and preferences, your water jacket can be installed using Convection / Thermosyphon Water Recirculating System or a Pumped / Active System. If your storage tank is located below or a distance away from the stove, you will need to use the Pumped System. If you do not have access to, or do not wish to use electricity to circulate your water, you will want to use the Convection / Thermosyphon system.

## Convection / Thermosyphon Water Recirculating System

The thermosyphon, convection or gravity system relies on the principle that hot water rises and cool water falls, circulating water from the stove to the storage tank and back again. Cooler water from the bottom of the storage tank drops through the piping system to the water jacket, where it is heated. From here it travels back to the top of the storage tank. This is the most basic and dependable method of heating water with a woodstove, and will automatically deliver hot water to your storage tank any time there is heat in your stove's firebox.

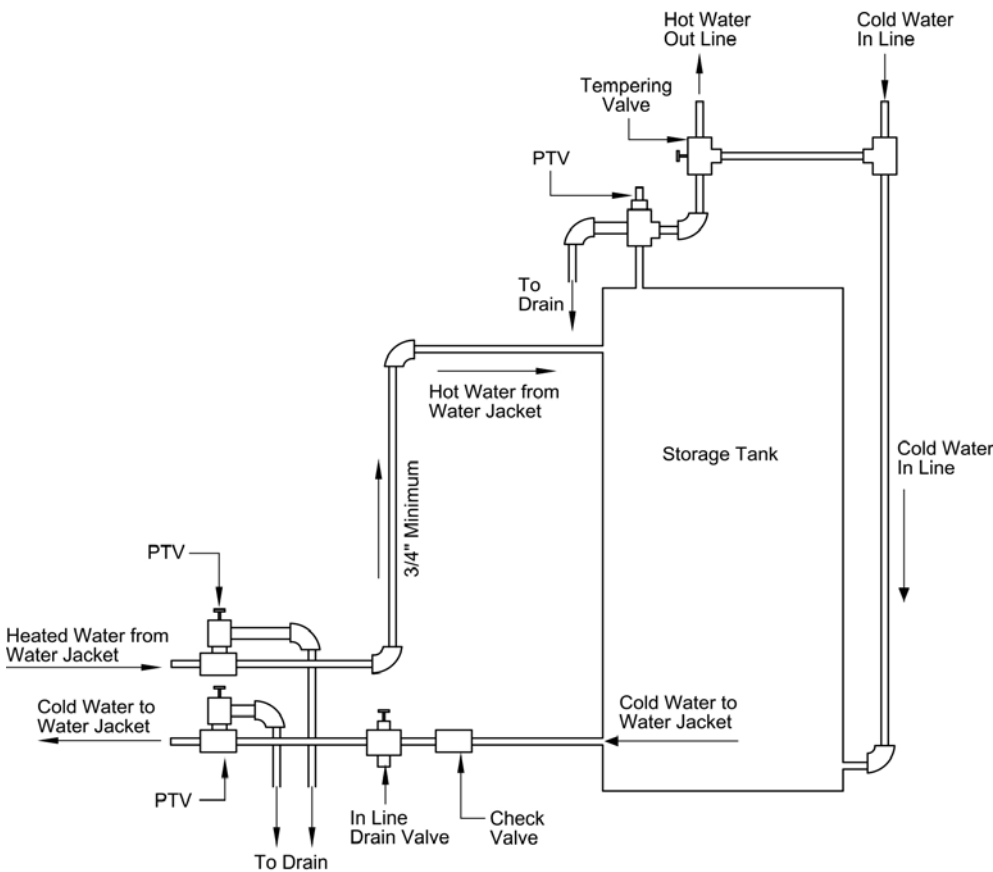

For this system to work properly, the cold water outlet on your storage tank must be placed higher than the cold water inlet on the water jacket. The formula for placement is ***one vertical foot higher for every two horizontal feet between the water jacket and the storage tank.*** (Example: if your storage tank is located four feet from the water jacket, the tank must be at least two feet higher than the water jacket.) Locate the storage tank within eight horizontal feet of the water jacket. For optimum performance, place the tank as high above the stove as possible.

Keep the piping as straight as possible and use as few 90 degree elbows as possible. (If you must use elbows, 45 degree elbows are preferred.) Use pipe of at least 3/4" diameter for the

water jacket-to-tank loop. The pipe must enter the top of the storage tank, and a 150 p.s.i. pressure temperature relief valve (PTV) must be installed on the top of the storage tank. All pressure temperature relief valves must be piped to a drain. Install a tempering valve in the hot water line above the pressure relief valve.

Install a check valve in the cold water line leading from the storage tank to the water jacket, in the line between the storage tank cold water outlet and the water jacket cold water inlet. The directional arrow on the check valve must face in the direction of the flow of water (i.e. must face in the direction of flow to the water jacket). Install a drain valve at the lowest point in the piping system.

**DO NOT INSTALL GATE VALVES ANYWHERE IN THE SYSTEM. IF THERE ARE GATE VALVES, AND THEY ARE LEFT CLOSED, IT WILL CAUSE DAMAGE TO THE SYSTEM AND COULD POSE A SERIOUS SAFETY RISK.**

All pipes should slope downwards slightly towards the water jacket to prevent air from being trapped in the line.

## Pumped / Active System

If your storage tank is located below the stove or a great distance from the stove, you will need to use the pumped / active system. With this system, an electric pump is used to circulate the water and a heat activated sensor is used to activate the pump when the stove is hot.

Caution: In the event of a power failure, water may stop moving and become highly pressurized in the water jacket and piping. An additional pressure temperature relief valve (PTV) must be located in the hot water line within two feet of the water jacket. The PTV must be installed according to local building and safety codes, and must be piped to a drain.

NOTE / DANGER: If you plan to use your water jacket during a power outage, you **MUST** have a source of cold water to replace any hot water you draw off for use. Failure to do so can cause an air lock at the top of the system. This will prevent thermosyphon circulation and could result in excessive pressure and explosion.

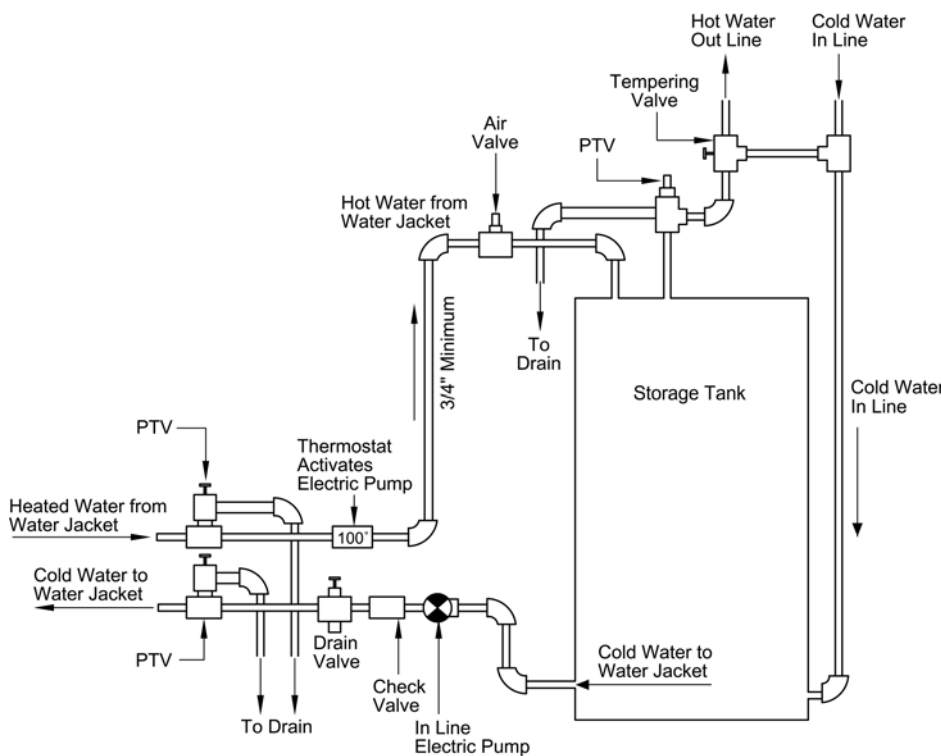

**DO NOT INSTALL GATE VALVES ANYWHERE IN THE SYSTEM. IF THERE ARE GATE VALVES, AND THEY ARE LEFT CLOSED, IT WILL CAUSE DAMAGE TO THE SYSTEM AND COULD POSE A SERIOUS SAFETY RISK.**

## Installation

It may be difficult to find all of the fittings required at your local plumbing or hardware store. If you require parts that you are unable to find, you can order them through:

Lehman Hardware  
One Lehman Circle, P.O. Box 270  
Kidron, Ohio 44636  
888-438-5346  
www.lehmans.com

NOTE: Any time the installer is connecting different metals to each other (i.e. stainless steel to steel, steel to copper, etc.), they must use a brass nipple\*. If this method is not used, electrolysis between the different metals will cause the pipe to break down and leak. Use steel or brass pipe and fittings on any line within three feet of the water jacket. Do not use copper fittings within three feet of the stove – in the event water flow stops, heat will rapidly build up in the pipe and melt soldered joints, causing leakage and potential safety hazards.

\* Some local building codes require dielectric unions rather than brass nipples. Although brass nipples are a better alternative (the plastic gasket in dielectric unions can melt at extreme temperatures), you must comply with local building codes.

If you have a heat shield installed on your stove, the shield will have to be removed prior to installing the water jacket. The shield must be replaced after installing the water jacket if you wish to maintain clearances applicable to a shielded stove.

1. Allow the stove and firebox to cool completely. Remove all ash and debris from the firebox.
2. Remove the left cookplate: Lift the left side of the plate. Slide the plate slightly to the left (out from under the next cookplate). While guiding the lifter handle (if the lifter is attached) through the cabinet bracket, lift the plate off of the stove. Set aside.
3. Remove the retaining clip holding the top of the rear fire brick. While standing behind the stove, hold the clip and undo the screw on the back of the range which holds the clip in place. (If you have a heat shield, the side section may have to be removed to access the screw.)
4. Carefully remove the brick and store.
5. Remove the two 1-1/2" x 2-1/2" plates (on the back of the stove behind the firebox) that cover the water jacket holes.
6. Install two 1-1/2" x 3/4" brass nipples into the water jacket.
7. Set the water jacket into the firebox in the position from which you removed the rear fire brick, carefully guiding the pipe nipples through the holes in the back of the firebox.
8. Replace the brick retainer clip removed in step 3.
9. You can route your hot and cold water lines out the space between the top of the heat shield and the back of the splashback, or you can route them out through the side of the heat shield. (Use the template provided to cut notches in the heat shield so it can be removed and replaced with the pipes in place. Do not exceed the cutout dimensions on the template, as this will compromise the effectiveness of the heat shield.)

Location of Waterjacket Holes for Rough-in Calculations

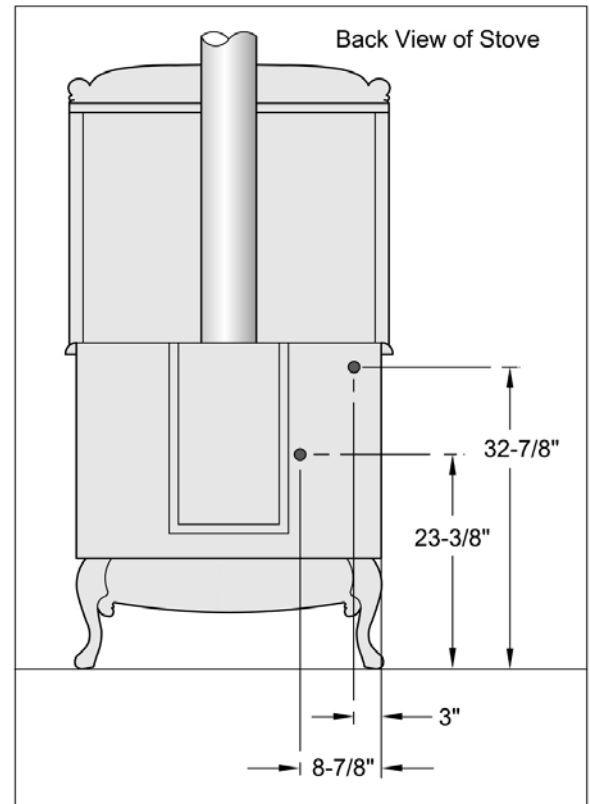

Your water jacket is now installed in the firebox, and is ready for the plumbing to be connected. Contact a qualified plumbing contractor for the balance of the installation.

An **air valve / vent**, rated to 150 p.s.i., must be installed in the highest point in the system where air bubbles might become trapped, and in any other “loop” where air pockets might develop.

A **check valve** must be installed in the cold water line leading from the storage tank to the water jacket to prevent flow reversal. The arrow on the check valve must point in the direction of water flow (towards the water jacket). Use only a “swing gate” check valve, not a spring-loaded check valve. (Most swing gate valves must be installed in a horizontal run of pipe.)

Install a **drain valve** between the water jacket and check valve. Do not install the check valve between the jacket and drain; it will prevent the jacket from draining when you drain the system.

## Maintenance

Free-flowing water is a very effective coolant – the flow of water to and through your water jacket will help to ensure a long life. Even though your firebox may be extremely hot, if your system is maintained properly and water is carrying heat away from the jacket, the temperature of the water jacket should always remain moderate.

Lime and sediment build-up will eventually begin to restrict the flow of water through the water jacket. The frequency with which maintenance will be required will vary, depending on the concentration of minerals or sediment in your water. Clean the water jacket at least once per year, or any time water heats more slowly than normal. There are two effective methods for cleaning your water jacket:

1. Remove the water jacket and take it to your local radiator repair shop. For a modest charge, they can “boil” residues and build-up out of the jacket.
2. Remove the jacket and lay flat, with plumbing fittings facing up. Fill the jacket with a solution of 75% vinegar, 25% clean clear water. Let stand for six hours. Flush thoroughly with a garden hose and re-install. After cleaning, the water jacket should be pressure tested to ensure it has not been weakened by cleaning or corrosion.

## Tips & Trouble Shooting

### Pressure Temperature Release Valves Fire Too Frequently:

PTVs release when the water in them becomes too hot. This can be caused by a number of factors:

- Poor / slow circulation of water. Possible solutions include moving the storage tank higher and closer to the stove, eliminating elbows and / or replacing 90 degree elbows with 45 degree elbows.
- Rapid heating of the water jacket. If the water in the jacket is heated too quickly, before thermosyphon circulation is established, the water in the jacket and at the first PTV may be excessively hot. This problem can often be corrected by warming the stove more gradually, allowing circulation to establish before building a full hot fire.
- Lack of hot water use or excess heating capacity. If hot water is not being drawn out of the system frequently enough, the entire system may overheat. Especially when operating your stove at high temperatures, occasionally run hot water to reduce the water temperature in the system. Alternatively, you can increase the size of the storage tank and / or remove some of the insulation from the pipes and storage tank.
- If the suggestions above do not remedy the problem, and if possible, install a circulating pump.

DO NOT move the PTV further from the water jacket. The PTV only releases because safe pressure limits have been exceeded.

### Tips:

- Because of mass manufacturing efficiencies, a conventional hot water heater, left disconnected from gas or electricity supplies, is probably the most cost-effective storage tank you can purchase.
- To prevent property damage, put a drain pan under any storage tank that is located above living space or materials you wish to protect from potential water damage.
- Use 50/50 solder when installing copper pipe.
- Use fine sandpaper to clean copper pipe for soldering.
- Use Teflon plumbing tape on all threaded joints.
- Wrap hot water pipes with insulation to minimize heat loss. (Exception: if your system is continually overheating and firing PTVs, you may wish to allow some heat loss through the pipes.)